

# Stuttgart Small Satellite Program

The program's long term goals are the launch and operation of small satellites in orbit for evaluation of new technologies, Earth observation and lunar exploration. The completion of 3 satellites is planned until the end of this decade.

All satellites will be designed, built and operated by the Institute of Space Systems.

## Flying Laptop

is the first micro-satellite built at the University of Stuttgart for Earth observation and technology demonstration.

The 'rent-a-sat' mode allows external customers to use the satellite for in-space evaluation of their software algorithms. Customer specific loadable CPU cores and full access to the satellite subsystems are provided.

## Science

- multispectral earth observation
- BRDF measurement
- precipitation measurement via Ka-band
- determination of trace gases

## Technology evaluation

- FPGA on-board computer
- high speed Ka-band communication
- SANTANA generator test bed

3-axis stabilized (momentum wheels)  
target pointing mode  
2 cameras (VIS/NIR,TIR)

TM&TC: UHF, S-band  
TWT amplifier: Ka-band

solar panel size: 1 m<sup>2</sup>  
max. power: 200 W  
mass < 100 kg

polar orbit, ~700km altitude  
piggyback launch 2006

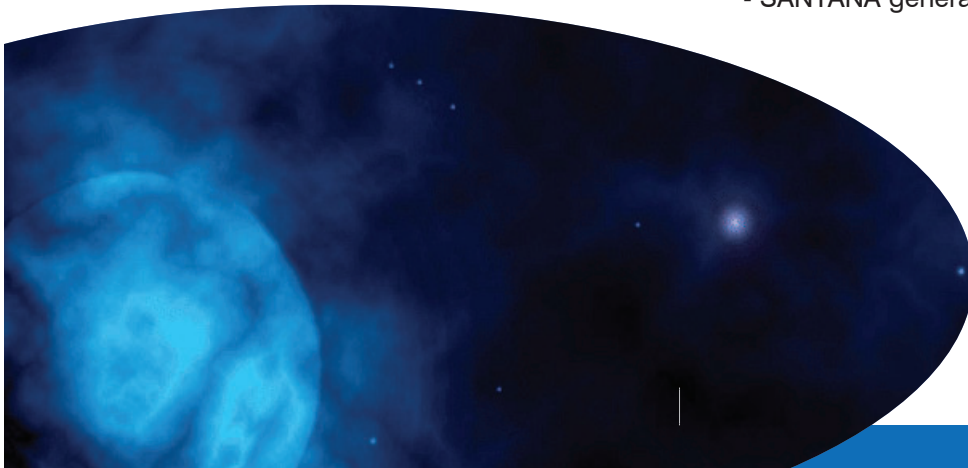
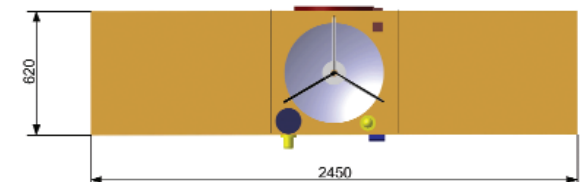
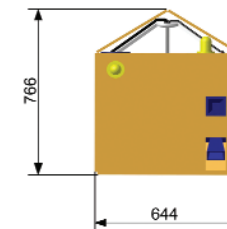



DLR



EADS Astrium



Fraunhofer Institut



Opto-System-Technik



STZ Raumfahrt



TU Berlin



TU Braunschweig

head  
project manager  
administration  
science  
electronics  
communication  
service subsystems  
design  
payload

H.P. Röser  
F. Huber  
T. Wegmann  
M. v. Schönemark  
M. Hartling  
G. Kühnhardt  
G. Grillmayer  
M. Lengowski  
S. Walz

Email: [flyinglaptop@irs.uni-stuttgart.de](mailto:flyinglaptop@irs.uni-stuttgart.de)  
<http://www.irs.uni-stuttgart.de>

# Flying Laptop

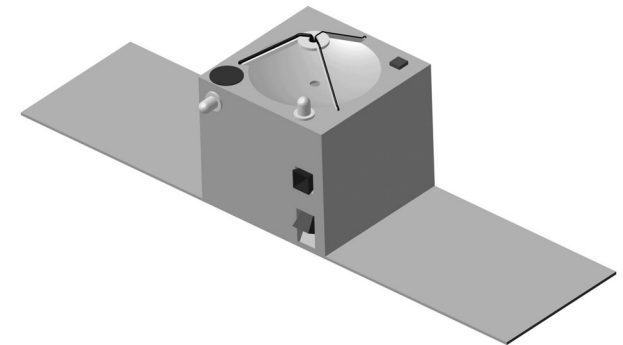

Institute of Space Systems - University of Stuttgart - Germany

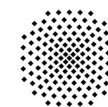

University of Stuttgart

